

“Profitable and proprietary know-how for cost-saving”

Success key factor for becoming quickly competitive and leader on the market

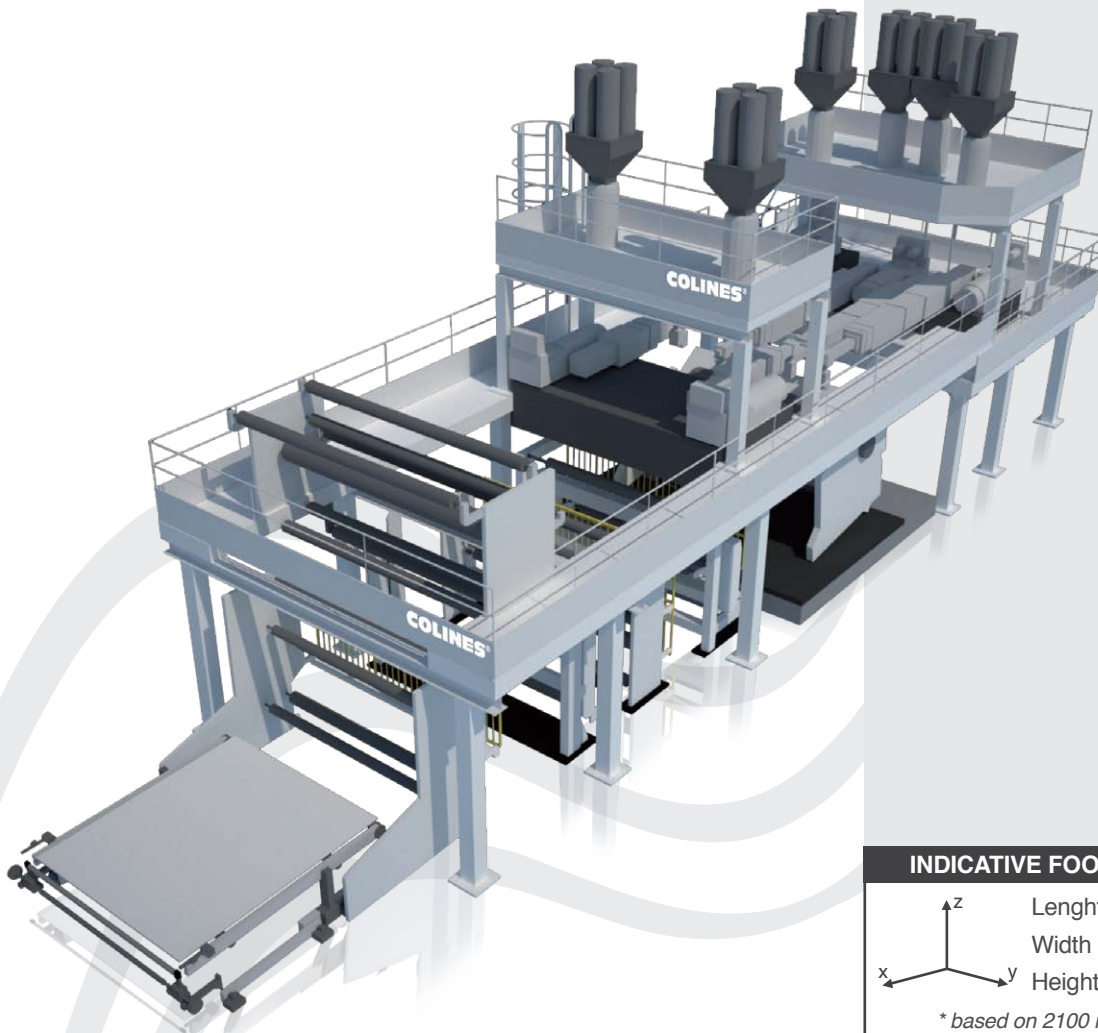

INDICATIVE FOOTPRINT*

	Length (x)	17 m
	Width (y)	6 m
	Height (z)	8 m

* based on 2100 mm line

Thanks to our process of verticalization (engineering and manufacturing of the lines + film production i.e. formulations and applications) we gained a comprehensive expertise in barrier film. This is why we can guarantee excellence in engineering and reliability of the lines, a deep knowledge in raw materials, their combinations, film production and market demand, mainly in food, medical and pharma packaging.



barrier cast®

Cast lines for barrier film



COLINES®

Main technical data/features:

- Thickness 25÷300 µm
- Stratification up to 11 layers
- Raw materials: PE, PP, EVA, TL, EVOH, PA, PET, PS and bio-based PLA, PVOH, etc..
- Lateral trims scrap down to 25 mm per side depending on the film produced
- Dittering® and Refesave® proprietary system for the highest quality and cost-saving
- Encapsulation and decking system
- In-line film quality inspection



SCRAPLESS by Elav®
 Fast procedure for production change
 No production interruption
 Cut down your scraps

ESSENTIAL FOR BARRIER FILM

Electronic package

by www.elav.it

- HMI
- Inbox
- Live control
- Easy key
- Fast adjust
- Teleservice
- Videoservice
- Remote supervisor

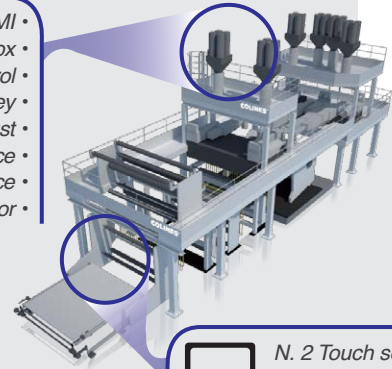

inb
HMI
 work with
 Smartphone
 and Tablets



N. 2 Touch screen Siemens
 Industrial PCs included as
 standard equipment



Food



Medical



Lamination



Hot lamination



COLINES®

Colines® S.p.A. (Novara Factory)
BarrierCast® Division
 Via Buonarroti, 27/29 - 28060 S.P. Mosezzo, Nibbia (NO) - Italy
 Ph. +39 0321 486311 - Fax +39 0321 486355
www.colines.it - info@colines.it



Crisp177.it

BC13EN01

BarrierCast®

BarrierBlown®

Novara factory